

Presentation

Emergency stop trip wire switches are designed to :

- avert hazards (dangerous phenomena) at the earliest possible moment, or to reduce existing risks which could cause injury to persons or damage to either machines or to work in progress,
- be tripped by a single human action when a normal Emergency stop function is not suitable,
- trip in the event of the trip wire breaking.

Emergency stop trip wire switches are essential in premises and on machines which are dangerous when in operation. The operator must be able to trigger the stop instruction at any point within his working area.

Application examples : woodworking machines, cutting presses, conveyor systems, transfer machines, printing and textile machines, rolling mills, test laboratories, paint shops, surface treatment works.

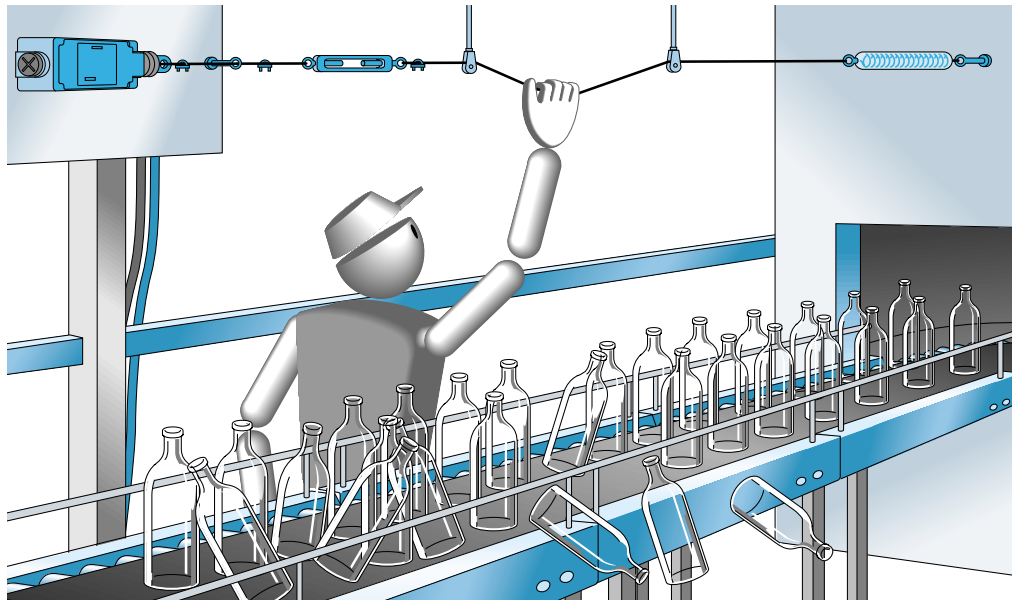

Setting-up

Typical installation

- | | | |
|---------------------|-------------------------------|-----------------------|
| 1 Fixing support | 2 Emergency stop | 3 First cable support |
| 4 Switch adjustment | 5 Cable grips | 6 Turnbuckle |
| 7 End spring | 8 Pulley supports and pulleys | |

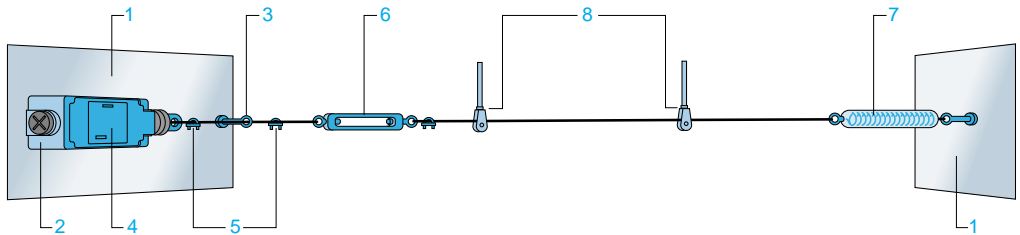

Notes

All XY2-CH/CE/CB trip wire switches can be fitted with a pilot light to indicate that the switch has been tripped. It is essential that pulleys be used with trip wires that deviate from a straight run, i.e. angled to form a protected zone. Important : The total sum of the angles through which the trip wire bends must be less than 180°.

Main features

1 Positive operation : the switches incorporate positive opening operation contacts, the tripping of the switch being made with positive action.

2 Latching : the switch latches in the tripped position (N/C safety contact(s) open). The function of the N/O contact is purely for signalling.

3 Resetting : the switches incorporate a reset button, which re-closes the safety contact(s). Restarting of the machine must only be achieved by manual operation of a control device within the machine start circuit, remote to the trip wire switch.

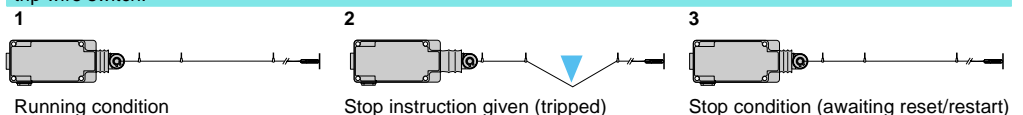

Trip wire expansion and contraction : d

Temperature variations likely to be encountered in the protected zone will obviously cause the trip wire to expand or contract. To enable instant verification that the trip wire is at its correct tension (and for making any necessary adjustments), XY2-CH and XY2-CE switches incorporate a trip wire tension indicator.

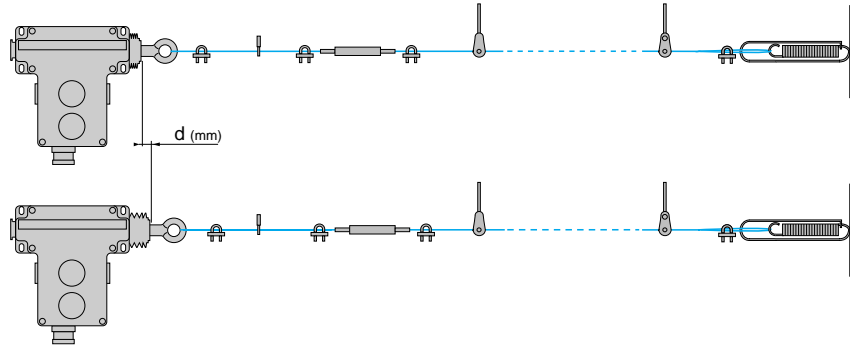

**Tripping force : F1
Tripping deflection : f**

The tripping force **F1** is the force necessary on the trip wire to cause the switch to trip. The tripping deflection **f** is the distance that the trip wire has to be deflected from its taut position to the point at which the switch trips.

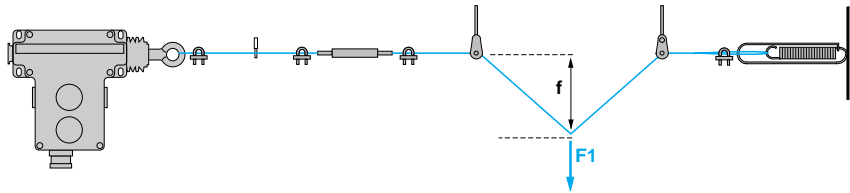

Adjustment values

For Emergency stop trip wire switches type XY2-CE : the adjustment values depend on the positions of the cam located inside the switch. Adjustment is made by rotating the cam after the switch has been installed. Each notched position of the cam is referenced by the letters A to F, and the selected letter is visible through a viewing port. Temperature range : < 25 °C.

Type	Position of cam	Average tripping deflection and tripping force values for a distance between cable supports of : 5 m for XY2-CH, 5 m for XY2-CE and 20 m for XY2-CB			
		Deflection f for :		Force F1	
		Light force mm	Standard force mm	Light daN	Standard daN
XY2-CE	A	160	160	2	3.2
	B	170	175	2.4	3.8
	C	180	190	2.8	4.4
	D	190	200	3.2	4.9
	E	200	210	3.5	5.6
	F	205	220	3.9	6
XY2-CH	—	—	160	—	2
XY2-CB	—	—	350	—	6

Standards

XY2-CH, CE and CB trip wire switches meet all the requirements of the harmonised European standard **EN 418**, relating to Emergency stop devices. The use of an end spring is strongly advised in the recommendations of the European draft standard **prEN 616**, when using trip wire switches on continuous duty mechanical handling equipment and systems. All the trip wire switches carry the **CE** mark and are delivered with an EC declaration of conformity.

Environment	
Conforming to standards	Products: XY2-CB: IEC EN 947-5-1, EN 60947-5-1, VDE 0660-200, CSA C 22-2 n° 14, prEN616 XY2-CE, CH, CB: IEC EN 947-5-1, EN 60 947-5-1, VDE 0660-200, EN 418, prEN616 Machine assemblies: XY2-CE, CH, CB: EN 60 204-1, EN 292, Machinery Directive: 98/37/CE and 91/368/EEC. Use of Work Equipment Directive: 89/655/EEC
Product certifications	Special version XY2-CB: CSA ~ 600 V heavy duty. XY2-CE: UL-CSA A 300-Q 300. XY2-CH: UL-CSA
Protective treatment	Standard version: "TC". Special version: "TH"
Ambient air temperature	Operation: - 25...+ 70 °C. Storage: - 40...+ 70 °C
Vibration resistance	XY2-CE: 10 gn (10...300 Hz) conforming to IEC EN 68-2-6; XY2-CH: 10 gn (10...150 Hz)
Shock resistance	XY2-CE, CH: 50 gn (duration 11 ms) conforming to IEC EN 68-2-27
Electric shock protection	Class I conforming to IEC EN 536 and NF C 20-030 XY2-CB: enclosure IP 22, contact housing IP 65, conforming to IEC EN 529 and NF C 20-010 XY2-CE, CH: IP 65
Degree of protection	XY2-CE, CH (Emergency stop): 10,000 operating cycles
Mechanical durability	XY2-CE, CH (Emergency stop): 10,000 operating cycles
Length of protected zone (trip wire)	XY2-CH: ≤ 15 metres, XY2-CE: ≤ 50 metres, XY2-CB: 100 metres and 200 metres
Cable entry	See dimensions, page 38145/9.

Contact block characteristics

Rated operational characteristics	AC-15: A 300 or Ue = 240 V, Ie = 3 A DC-13: Q 300 or Ue = 250 V, Ie = 0.27 A conforming to IEC EN 947-5-1 Appendix A, EN 60 947-5-1
Nominal thermal current	10 A
Rated insulation voltage	XY2-CE, CH: Ui = 500 V degree of pollution 3 conforming to IEC EN 947-1, Ui = 300 V to UL 508, CSA C22-2 n° 14 XY2-CB: Ui = 500 V degree of pollution 3 conforming to IEC EN 947-1, Ui = 600 V conforming to CSA C22-2 n° 14
Rated impulse withstand voltage	XY2-CE, CH: U imp = 6 kV conforming to IEC EN 947-1, IEC EN 664
Positive operation	N/C with positive opening operation conforming to IEC EN 947-5-1 Section 3, EN 60 947-5-1
Contact operation	XY2-CB, CE, CH (Emergency stop): N/C + N/C or N/C + N/O slow break
Resistance across terminals	≤ 25 mΩ conforming to NF C 93-050 method A or IEC EN 255-7 category 3
Terminal referencing	Conforming to CENELEC EN 50013
Operational voltage	~ 24...380 V
Short-circuit protection	XY2-CB, CE, CH: 10 A cartridge fuse type gG (gl) conforming to IEC EN 269

Rated operational power
(Electrical durability)
Operating rate: 3600 operating cycles/hour
Load factor: 0.5

XY2-CB
Conforming to IEC EN 947-5-1 Appendix C
Utilisation categories AC-15 and DC-13
a.c. supply ~ 50...60 Hz
Power broken in VA (1)
⌘ Inductive circuit

Voltage V	24	48	127	220
⌘ VA	250	250	500	500

d.c. supply ---
Power broken in W (1)
⌘ Inductive circuit

Voltage V	24	48	120
⌘ W	50	100	100

(1) For 1 million operating cycles

XY2-CE, CH
Conforming to IEC EN 947-5-1 Appendix C
Utilisation categories AC-15 and DC-13
a.c. supply ~ 50...60 Hz

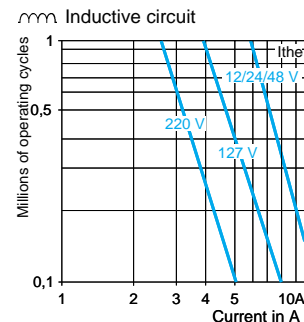

Voltage V	24	48	120
⌘ W	15	23	30

Cabling	Screw clamp terminals, clamping capacity: min. 1 x 0.5 mm ² , max. 1 x 2.5 mm ² or 2 x 1.5 mm ²
---------	--

Safety solutions using Preventa

Emergency stop trip wire switches



XY2-CH13250



XY2-CE1A250



XY2-CB30

Latching Emergency stops without pilot light (1) (cable not included)

Contact	Reset	Cable anchor point	Reference	Weight kg
Length of cable ≤ 15 metres. Distance between cable supports: 5 metres				
N/C + N/O slow break	By booted pushbutton	RH side or LH side	XY2-CH13250 (3)	0.865
	By key release pushbutton (key n° 421) (2)	RH side or LH side	XY2-CH13450 (3)	0.910
N/C + N/C slow break	By booted pushbutton	RH side or LH side	XY2-CH13270 (3)	0.865
	By key release pushbutton (key n° 421) (2)	RH side or LH side	XY2-CH13470 (3)	0.910
Length of cable ≤ 50 metres. Distance between cable supports: 5 metres				
N/C + N/O slow break	By booted pushbutton	RH side	XY2-CE1A250	1.450
		LH side	XY2-CE2A250	1.450
N/C + N/C slow break	By booted pushbutton	RH side	XY2-CE1A270	1.450
		LH side	XY2-CE2A270	1.450
N/C + N/O slow break	By key release pushbutton (key n° 421) (2)	RH side	XY2-CE1A450	1.465
		LH side	XY2-CE2A450	1.465
N/C + N/C slow break	By key release pushbutton (key n° 421) (2)	RH side	XY2-CE1A470	1.470
		LH side	XY2-CE2A470	1.470
Length of cable ≤ 100 metres. Distance between cable supports: 20 metres				
N/C + N/O slow break	From inside enclosure	LH side	XY2-CB10 (4)	15.000
		RH side	XY2-CB20 (4)	15.000
Length of cable ≤ 2 x 100 metres. Distance between cable supports: 20 metres				
N/C + N/O slow break	From inside enclosure	RH and LH sides	XY2-CB30 (4)	25.000

Latching Emergency stops with pilot light (cable not included)

Contact	Reset	Supply (direct) Bulb included	Cable anchor point	Reference	Weight kg
Length of cable ≤ 50 metres. Distance between cable supports: 5 metres					
2 N/C + N/O slow break	By booted pushbutton	230 V	RH side	XY2-CE1A297	1.470
			LH side	XY2-CE2A297	1.470
Contact	Reset	Supply (via integral transformer) (5)	Cable anchor point	Reference	Weight kg
Length of cable ≤ 100 metres. Distance between cable supports: 20 metres					
N/C + N/O slow break	From inside enclosure	24 V/6 V	LH side	XY2-CB11 (4)	15.600
			RH side	XY2-CB21 (4)	15.600
		127 V/6 V	LH side	XY2-CB13 (4)	15.600
			RH side	XY2-CB23 (4)	15.600
		220 V/6 V	LH side	XY2-CB14 (4)	15.600
			RH side	XY2-CB24 (4)	15.600
Length of cable ≤ 2 x 100 metres. Distance between cable supports: 20 metres					
N/C + N/O slow break	From inside enclosure	24 V/6 V	RH and LH sides	XY2-CB31 (4)	25.600
			RH and LH sides	XY2-CB33 (4)	25.600
			RH and LH sides	XY2-CB34 (4)	25.600

(1) These Emergency stops are also available fitted with a pilot light, see ordering forms for XY2-CH and XY2-CE trip wire switches on pages 38145/4 and 38145/5.

(2) Ø 30 mm mushroom head key release pushbutton. Locking and key withdrawal in the rest (unactuated) position.

(3) For the ISO M20 threaded cable entry version, add the suffix **H29** to the selected reference. Example: **XY2-CH13250** becomes **XY2-CH13250H29**.

(4) End spring included for XY2-CB.

(5) BA 7s - 6 V bulb included.

Other versions See order forms, pages 38145/4 and 38145/5.
XY2-CE with reset by Ø 40 mm mushroom head pushbutton or with integral cable tensioner & support. Please consult your Regional Sales Office.



XY2-CZ402



XY2-CZ503



XY2-CZ524



XY2-CZ601

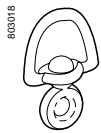

XY2-CZ602

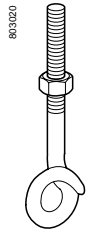

XY2-CZ705



XY2-CZ708



XY2-CZ701



XY2-CZ702

Description	For use with	Diameter	Length	Reference	Weight
		mm	m		
Galvanised cables with red sheath	XY2-CH	3.2	10.5	XY2-CZ301	0.280
			15.5	XY2-CZ3015	0.410
			25.5	XY2-CZ302	0.690
			50.5	XY2-CZ305	1.360
			100.5	XY2-CZ310	2.700
XY2-CH, XY2-CE and XY2-CB		5	15.5	XY2-CZ1015	0.850
			25.5	XY2-CZ102	1.400
			50.5	XY2-CZ105	2.750
			100.5	XY2-CZ110	5.500
Sold in lots of					
Turnbuckles	M6 x 60 + locknut	All models except XY2-CH (1)	1	XY2-CZ402	0.060
	M8 x 70 + locknut	All models except XY2-CH (1)	1	XY2-CZ404	0.100
Cable grips	Single	Cable Ø 3 to 5 mm	10	XY2-CZ503	0.007
			10	XY2-CZ513	0.016
	Clamp	Cable Ø 3.2 mm	10	XY2-CZ523	0.050
			10	XY2-CZ524	0.080
Cable supports	Fixed	All models	10	XY2-CZ601	0.030
	Swivelling	All models	1	XY2-CZ602	0.130
	Pulley bracket	All models	1	XY2-CZ705	0.060
Pulley	Cable Ø 5 mm max.	All models	1	XY2-CZ708	0.002
Cable end protectors		Cable Ø 3.2 mm	10	XY2-CZ701	0.002
		Cable Ø 5 mm	10	XY2-CZ704	0.010
End springs		For XY2-CE	1	XY2-CZ702	0.080
		For XY2-CH	1	XY2-CZ703	0.035
		For XY2-CB	1	XY2-CZ707	0.080

Documentation

Description	For use with	Reference	Weight
			kg
Installation manual	All XY2-C trip wire switches	XCOM2512	0.200

(1) Emergency stop trip wire switches XY2-CH incorporate a cable tensioner as standard.

XY2-CE●A●●●

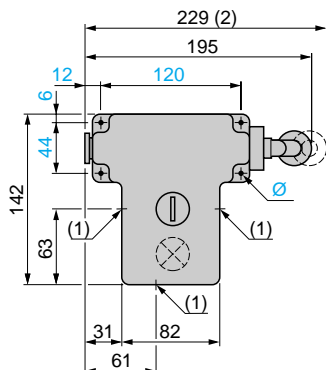

XY2-CE●A●●● + XY2-CZ917

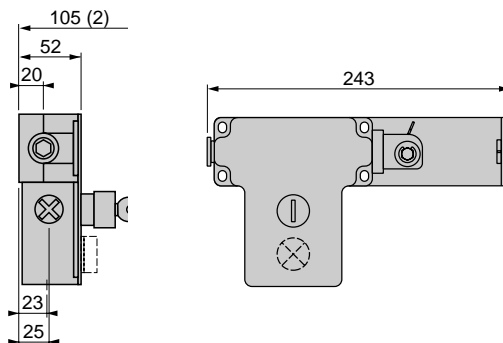

(1) 3 plain holes for n° 13 (Pg 13.5) or ISO M20 cable gland

(2) Maximum extension

Ø: 4 elongated holes Ø 6 mm

XY2-CB●●

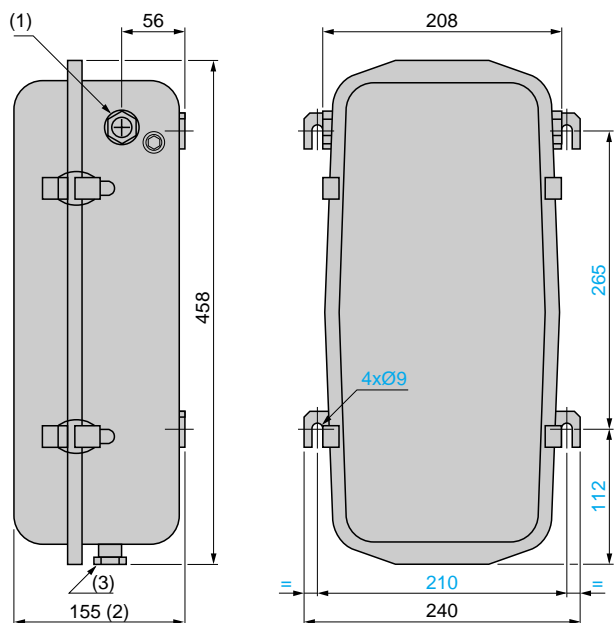

XY2-CH13●50

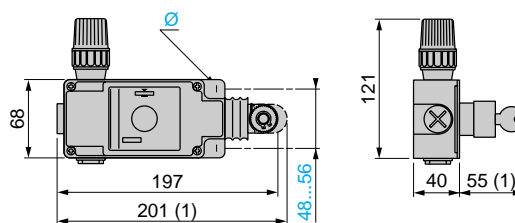

(1) Maximum extension

Ø: 2 elongated holes Ø 8 mm

(2) Tapped entries for n° 13 (Pg 13.5) cable gland.

For ISO M20, the reference becomes XY2-CH13●50H29.

(1) 2 access points for operating cable

(2) + 125 for opening of cover

(3) 1 tapped entry for n° 13 (Pg 13.5) cable gland

For ISO M20, use adaptor DE9-RP13520.

XY2-CZ705

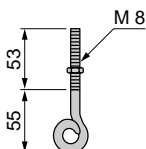

XY2-CZ708

