

Inductive sensor
Bi1-EG05-AP6X-V1331

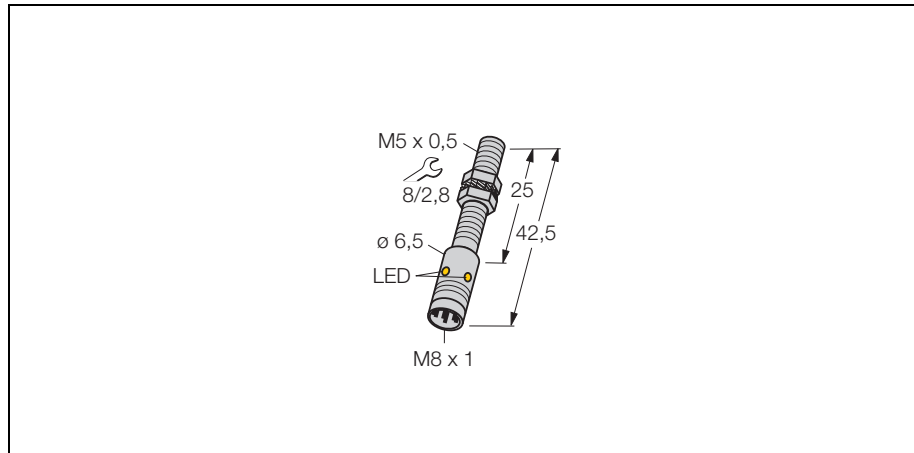

- threaded barrel, M5 x 0,5
- stainless steel, 1.4301
- 3-wire DC, 10...30 VDC
- normally open, pnp output
- connector, M8 x 1

Wiring diagram

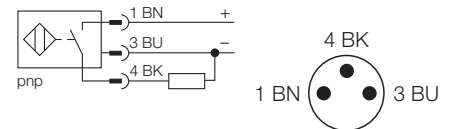

Type	Bi1-EG05-AP6X-V1331
Ident-No.	4608640
Rated operating distance Sn	1 mm
Mounting condition	flush
Assured sensing range	≤ (0,81 x Sn) mm
Correction factors	St37 = 1, V2A ~ 0.7, Ms ~ 0.4, Al ~ 0.3
Repeatability	≤ 2 %
Temperature drift	≤ ± 10 %
Hysteresis	3... 15 %
Ambient temperature	-25...+ 70 °C
Operating voltage	10... 30 VDC
Residual ripple	≤ 10 % U _{ss}
DC rated operational current	≤ 100 mA
No-load current I ₀	≤ 15 mA
Residual current	≤ 0.1 mA
Rated insulation voltage	≤ 0.5 kV
Short-circuit protection	yes / cyclic
Voltage drop at I _e	≤ 1.8 V
Wire breakage / Reverse polarity protection	yes / complete
Output function	3-wire, NO contact, PNP
Switching frequency	≤ 3kHz
Housing	threaded barrel, M5 x 0.5
Dimensions	42.5 mm
Housing material	metal, V4A (1.4404)
Material active face	Plastic, plastic, PA12-GF20
Tightening torque of housing nut	5 Nm
Electrical connection	Connectors, M8 x 1
Vibration resistance	55 Hz (1 mm)
Shock resistance	30g (11 ms)
Protection class	IP67
Display switch state	LED yellow

Functional principle

Inductive sensors are designed for wear-free and non-contact detection of metal objects. For this purpose they use a high-frequency electro-magnetic AC field that interacts with the target. Concerning inductive sensors, this field is generated by an LC resonant circuit with a ferrite core coil.

Inductive sensor
Bi1-EG05-AP6X-V1331

Mounting instructions	minimum distances
Distance D	2 x B
Distance W	3 x Sn
Distance T	3 x B
Distance S	1.5 x B
Distance G	6 x Sn

Diameter of the active area B \varnothing 5 mm

